

SIMPLE AND BEAUTIFUL EXPERIMENTS BY LADY CATS

Masako TANEMURA¹, Kyoko ISHII², Haruka ONISHI³, Chizuru HASHI⁴,
Fumiko OKIHARU⁵, Saori MIZUKO⁶, Sinobu RYUGO⁶, Kumi KAMBARA¹ and
Mika YOKOE¹

¹ Department of Practical School Education, Osaka Kyoiku University, 543-0054 Osaka, Japan

² Ochanomizu University Elementary School, 112-8610 Tokyo, Japan

³ Marugame Senior High School, Marugame, 763-0026 Kagawa, Japan

⁴ Fujii High School, Marugame, 763-0063 Kagawa, Japan

⁵ Department of Physics, Nihon University, 101-8308 Tokyo, Japan

⁶ Department of Science Education, Kagawa University, 760-8522 Kagawa, Japan

ABSTRACT

Many schoolgirls feel not much interest in physics. The physics woman teachers and researchers are minority, in Japan. Recently many primary teachers feel not much interest in physics, too. Actually, young primary teachers who have not studied physics at a high school and a college are increasing.

In order to change these tendencies, we have stood up and formed LADY CATS group in ICPE 2005. The feature of LADY CATS consists of women from elementary school teachers to university researchers. LADY CATS can show that women are enjoying physics.

Firstly, we plan to give all students enthusiasm for physics by performing simple scientific experiments. Key words for success must be as simple as possible but clearly showing essence of physics, for instance Paper-craft experiments, Talking cups, Cartesian divers, Double cone rolling upward, and so on. We believe this issue would be a great first step to young people's emotional concern to physics.



Acknowledgments

We are grateful to Ms. Saki KAGAMI and Mr. Masanori HIROI in Nihon University, Mr. Yasuo UNZAI in Owada Elementary School, Mr. Yoshiro HAMATSUKA and Mr. Akihiro MATSUI in Osaka Kyoiku University for their kind help during the demonstration.

Simple and Beautiful Experiments by LADY CATS

Inclined Plane and Double Cone

Masako TANEMURA

Osaka Kyoiku University, Tennoji, Osaka, 543-0054, Japan

1. What is an inclined plane and a double cone for?

This is an apparatus designed to about the movement of the center of gravity (Fig.1) . A double cone looks like going up on inclined plane, but in fact, its center of gravity is moving downwards on the plane(Fig.2).



Fig.1

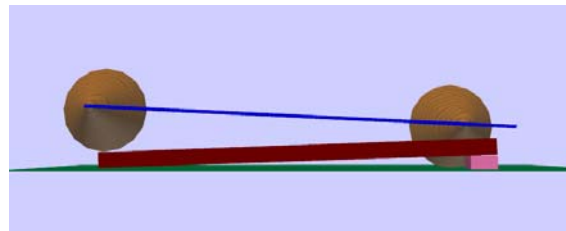

Fig.2

2. The way of conducting an experiment.

- ① Putting a double cone on the lower side of an inclined plane(Fig.1).
- ② Observing how it moves, afterwards.
- ③ Coordinating degrees of the opening of the inclined plane depending on shapes of a double cone.

3. How to make one.

- ① Using two cones and chopsticks (Fig.3).
- ② Pasting up two cones together with both-sided adhesive tape.
- ③ Fixing the ends of half-split chopsticks with tape and ensuring the chopsticks can open in the form of V.
- ④ Raising the other ends not fixed with tape.



Fig.3

Reference : J.J.Griffin & Sons, Scientific Handicraft,1910

PINWHEEL

FUN with the WIND!

Kyoko ISHII

Ochanomizu University Elementary School, Tokyo, Japan

E-mail: ishii.kyoko@ocha.ac.jp

Preparation: Colour Paper(ORIGAMI), Straw, Bomboo String,
Glue, Scissors, tapes

How to make ?

1. Make diagonal cuts at each corner.
(to 3 fingers length from the center)

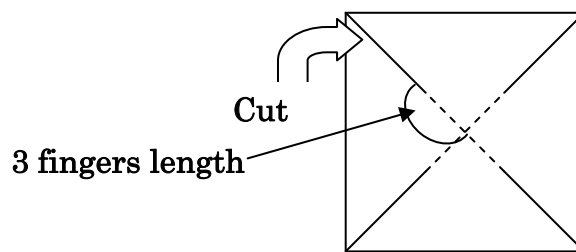

2. Glue 4 tops together at the center.
(wait 10 second till the glue dry)

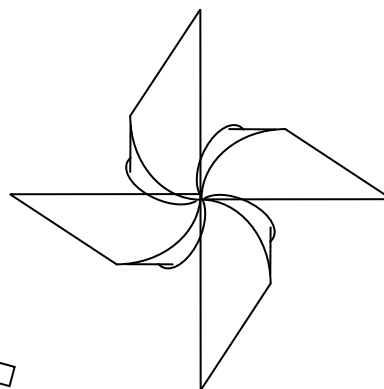

3. Make some slit at the end of straw.

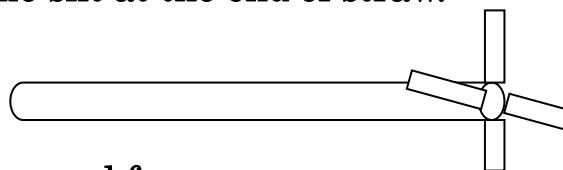

4. Stick straw and fun.

5. Run with PINWHELL
(2 fingers length)

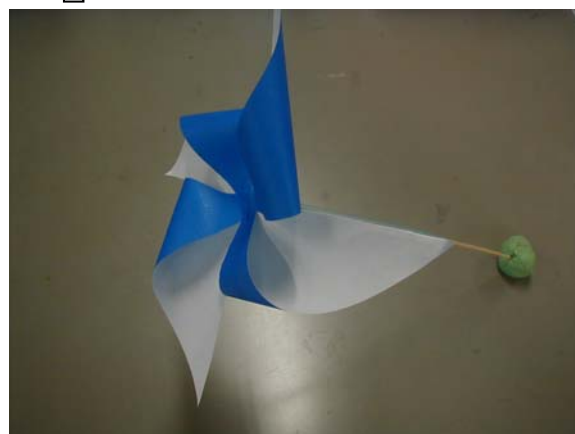

☆ Running CAT ☆

Haruka Onishi

Marugame Senior High School, JAPAN

E-mail: harukamimi2004@yahoo.co.jp

Preparation: Paper Cup, Straw (thin × 1 and thick × 1), Soft wire(15cm),
Drawing paper, Sticky tape, Scissors

How to make?

6. Pass the wire through the paper cup.
Bend the soft wire as shown in Fig.1.

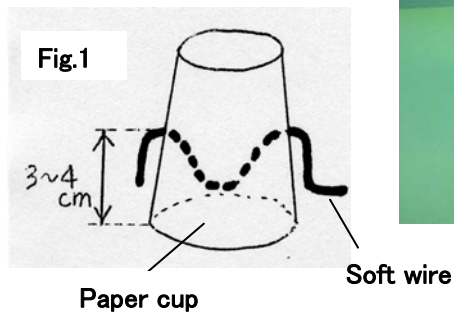

7. Cut the straws as shown in Fig.2.

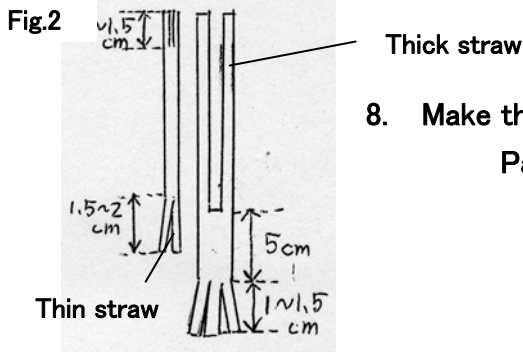

8. Make the hole in the bottom in the paper cup.

Pass the thin straw through there and fix it to the wire (Fig.3).

Fig.3

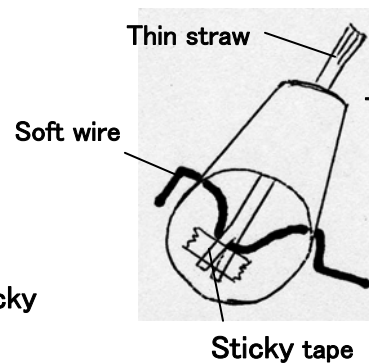
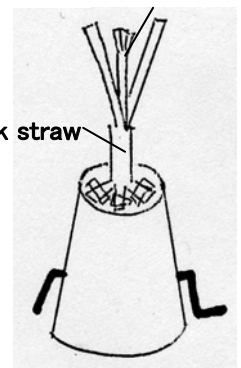

Fig.4 Thin straw



9. The bottom in the paper cup is taped up.
Pass the thick straw through the thin straw,
out side the cup.
Fix the thick straw to the paper cup with the sticky
tape (Fig.4).

10. Draw the Cat's face on the paper.
Connect A and A' from Fig. 5 with the sticky tape.

Fig.5

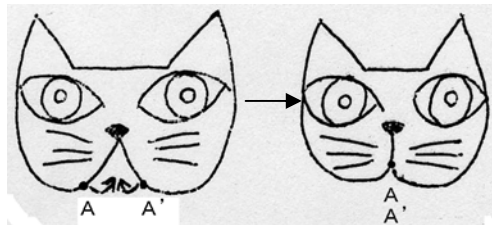

11. Fix the Cat's body to the thin straw with the sticky tape.
The Cat's head and tail are put on the thick straw with
the sticky tape (Fig.6).

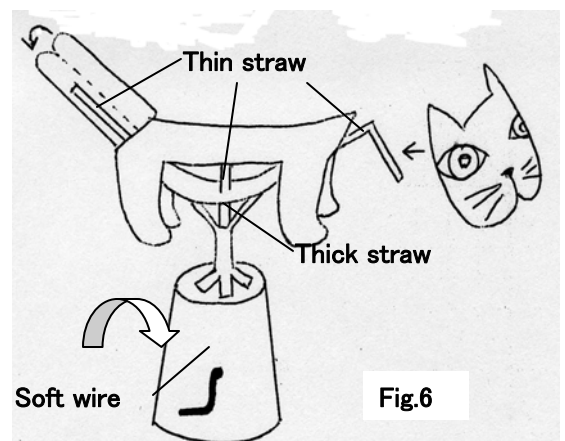

12. When the wire is turned, the paper cat will move like a cat running.

Reference: <http://www.flying-pig.co.jp/>

PAPER WHISTLE

Fujii High School Kagawa Japan

Chizuru Hashi

MATERIALS CARDBOARD, SCISSORS, PENCIL, STICKY TAPE, RULOR

PROCEDURE

1. Cut the cardboard like figure A by the scissors.

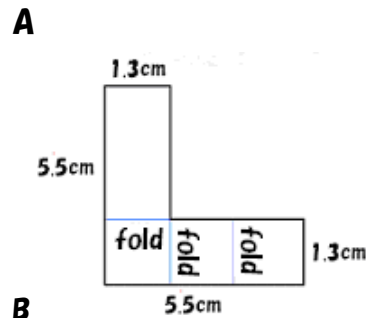

2. Fold and roll like figure B. And stick a tape on the end.

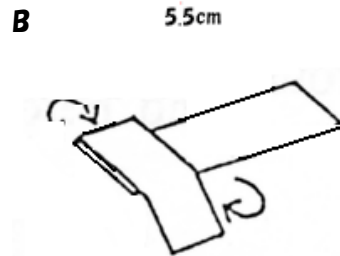

3. Form the cardboard into an open circle by pencil.

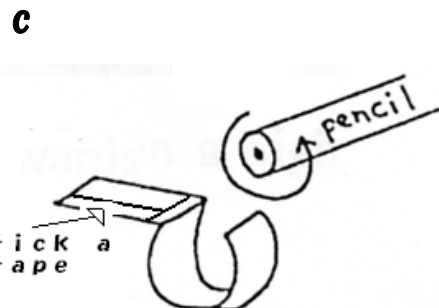

4. Hold the paper whistle tightly with your thumb and forefinger on both sides respectively. (C)

5. Blow strongly and be sure to have a space to pass enough air.

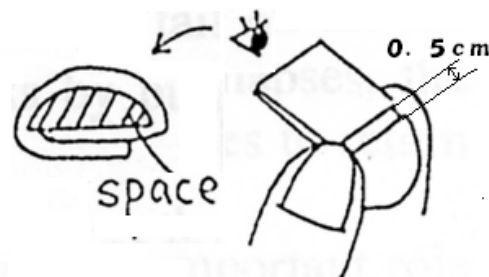

Source : 『 Science Play's Dictionary 』, Ohtsuka - Syoten, edited by Yoshiko Tuda, Japan

* 『PAPER CRAFT EXPERIMENTS 2』 by Shikoku Teachers & Lady Cats : International Conference on Physics Education 2005 New Delhi

String Telephone

~ Simple Communication to Network System ~

Fumiko Okiharu, E-mail: oharu@phys.cst.nihon-u.ac.jp

Dep. of Phys., Nihon University, 1-18-14 Kanda-Surugadai, Tokyo 101-8308, Japan

Simple String Telephone

Students may learn through this experiment how sound is transmitted in a substance.

Experimental Materials: Paper Cup (Plastic Cup) x 2 pieces, Cotton thread (Spring, Enamel Wire), Scotch tape, Awl, scissors, pasteboard etc.

How to make:

1. Punch a tiny hole on the bottom of each cup.
2. Put a string through a hole.
3. Fix the string end to the bottom of cup.



Let's try other materials instead of cotton thread and learn how it changes transmitting.

Application

String Telephone Network

Students may learn through this string telephone network system how plural sounds are transmitted in networking.

How to make:

1. Make up two or more sets of string telephone.
2. Bind the middle of each string.
3. Try to talk with more than three students.

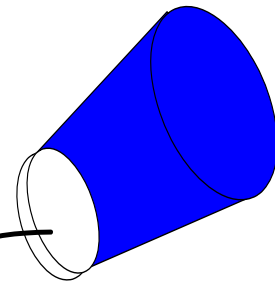

Echo Microphone

Students may learn through this echo microphone experiment how sound are transmitted and reflected in a plastic bottle.

Experimental Materials: Paper Cup x 2 pieces, Spring coil x 1 piece, Plastic bottle x 2 pieces, Scotch tape, Awl, Scissors, Pasteboard etc.

How to make:

1. Cut the top edge and bottom of plastic bottles.
2. Joint 2 bottles with scotch tape.
3. Punch a tiny hole on the bottom of each cup and fix the spring coil's end to the bottom of cups.
4. Put the cups and spring coil into the plastic bottle and fix them with scotch tape.



Reference: Jikken Club Copernicus, "Oto no fushigi wo kite miyou". Froebel-Kan (Publisher), in Japanese

DRAGONFLY

Shinobu RYUGO

Student of Kagawa University, Kagawa, Japan,

Using this teaching material, student will get the idea of "Center of Gravity".

<How to make>

1. Prepare the cardboard or the heavy grade of paper (Kent paper etc.).
2. The shape of it's body and wing is drawn on Figure 1.
3. The wing and the body are cut out with scissors.
4. It cuts between the wing and the wing, and four pieces are made a wing.
5. Connect the wing and body with the paste.(Figure2)

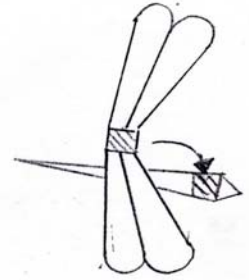

Figure2

<How to take balance>

First of all, the wing is bent below a little. Next, it adjusts it for the balance on the finger bending the head little by little.

The tail goes up by the large bend of the head below. Please cut the wing ahead little by little when you cannot take a right and left balance.

<Appreciate the mystery of paper Dragonfly>

It is balanced in a small point such as the tip of the finger.(Figure3)

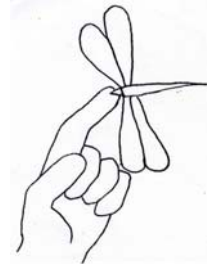

Figure3

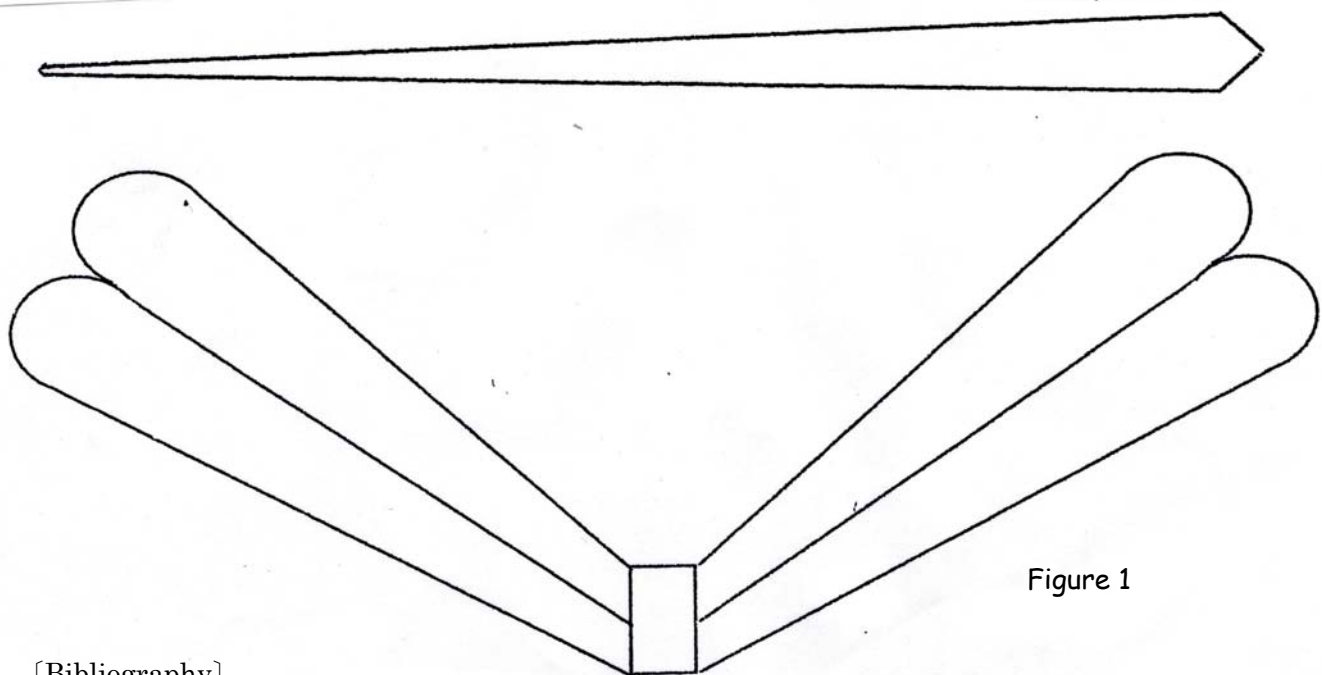

Figure 1

[Bibliography]

- International Conference on Physics Education, 2005, New Delhi
「Paper craft experiment 2」 by Shikoku Teachers & LADY CATS
- This is originally invented by Yuichi Tsugawa, *Tanosii jyugyou*,1994.

Cartesian Divers

Kumi KAMBARA

Osaka Kyoiku University
Tennoji, Osaka, 543-0054, Japan

As for the general Cartesian divers (figure 1), adjusting of water is difficult.

How, this one does not need difficult adjustments.

Glass beads are used as weights of the Cartesian divers.

Make a beautiful experimental with glass beads effectively to awakened interest and attention.

Materials

Glass beads (two kinds), Wire, Straw, Plastic bottle

How to make

Make a model of double spiral structure with beads and a wire.

It weights 13.3 g. The strew is outside diameter is 6 mm.

Cut the right and left from the edge of the straw's bellows to 13 mm.

Pass a wire through the straw.



(figure1)

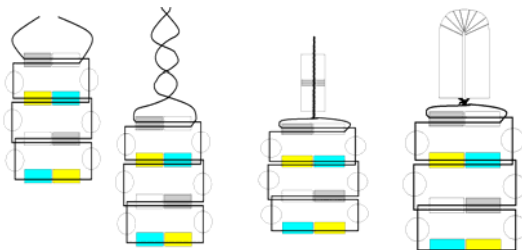

Bend the straw and fasten it.

Put the Cartesian diver in the cup filled with water.

Confirm whether it floats or not.

There should be the tip of bellows on the surface of the water. In case it sinks, cut someone wire.

Put this Cartesian diver into the plastic bottle filled with water and close the cover.

The experiment method

When you grasp the plastic bottle, the volume of the water does not change.

The volume of air in the Cartesian diver shrinks and it sinks.

When you let go your hold of the plastic bottle, the volume of the air in the Cartesian diver changes back and it floats.

The principle of Cartesian divers is based on Archimedes' principle.

Archimedes' principle

There is buoyant force in the liquid to make objects float.

If the gravity of an object is bigger than buoyancy, the object sinks,

There are floats.



References about Cartesian divers

① <http://g3400.nep.chubu.ac.jp/onsenkids/craft/atelie-f/inai-f.html>

② Shinji Danjo online natural science education network, Japan

③ "I will try to forget mysterious bodily sensation, a scientific experiment numerical formula!"
(ISBN: 4062572672) produced 1999.9

References about double spiral

① Society for Techno-innovation of Agriculture, Forestry and Fisheries (STAFF), Japan

② "Make a DNA carrying strap" from "Scientific festival 2006 guidebook"

Takao KITaura Osaka prefectural Ikuno High School, Japan

Self-moving Piece by the late TAKEKAWA

Mika YOKOE

Osaka Kyoiku University, Kashiwara, 582-0026, Japan

It is this origami which used the movement of the center of gravity. This was thought about around in 1935 by Mr. Seiryō TAKEKAWA. It is also known abroad now as one of the Japanese traditional works.

<How to make>

- (1) Fold the origami into half diagonally and open it. Fold A and B like the figure.
- (2) Fold C inward in a broken line inward.
- (3) Fold D and E inward like the figure.
- (4) Fold F inward in a broken line.
- (5) Fold G and H inward like the figure. (Repeat (3).)
- (6) Fold it into halves in a broken line.
- (7) Finish! ! Put it and with the long side below. What will happen?

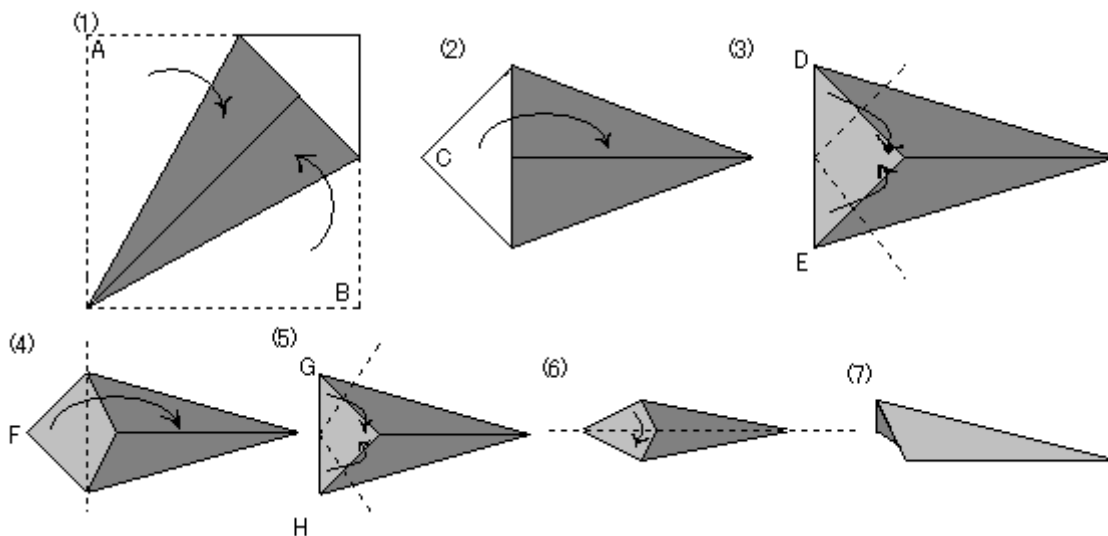

<Attention>

- ☆Put it on a flat mask.
- ☆Put it on the slippery plane.
- ☆Do not fold too tightly.
- ☆Let's think out to make it move well.

<Reference>

Yoshihide MOMODANI "Origamitejina" (ISBN4-416-30009-3) produced 2000,5

